

Dell™ Storage Solutions Guide for Microsoft® Hyper-V™

Notes and Cautions



NOTE: A NOTE indicates important information that helps you make better use of your computer.



CAUTION: A CAUTION indicates potential damage to hardware or loss of data if instructions are not followed.

Information in this document is subject to change without notice.

© 2008 Dell Inc. All rights reserved.

Reproduction of these materials in any manner whatsoever without the written permission of Dell Inc. is strictly forbidden.

Trademarks used in this text: *Dell*, the *DELL* logo, *PowerVault*, *EqualLogic*, and *CLARiiON* are trademarks of Dell Inc.; *Microsoft*, *Windows*, *Windows Server*, *Windows XP*, *MS-DOS*, *Hyper-V*, and *Windows Vista* are either trademarks or registered trademarks of Microsoft Corporation in the United States and/or other countries; EMC is the registered trademark of EMC Corporation; SUSE Linux Enterprise Server is a trademark of Novell, Inc. The abbreviation "SLES" is not a Novell trademark but is used here due to space constraints.

Other trademarks and trade names may be used in this document to refer to either the entities claiming the marks and names or their products. Dell Inc. disclaims any proprietary interest in trademarks and trade names other than its own.

Contents

Getting Started With Microsoft® Hyper-V™ Technology.	5
Understanding Hyper-V Architecture	5
iSCSI Connections Within the Guest OS	7
Storage Options for Virtual Machines (VMs) in Hyper-V	7
Disk Type	8
Disk Location	11
Disk Interface	13
Understanding the Storage I/O Path	15
Dell Supported Storage Arrays	17
iSCSI Arrays	18
Fibre Channel Arrays	25
SAS Arrays	27
Additional Dell Supported Storage Solutions	30
Internal Storage	30
Host-Based RAID With External Enclosures	30
Sizing Storage for Your VM	30
Sizing for VHDs	32
Sizing for Passthrough Disks	33
Direct iSCSI Connectivity Within Guest OS	34
iSCSI Connections from Both the Parent Partition and Guest OS	34
Direct iSCSI Connection Storage I/O Path	35
iSCSI Connection Summary	36

Appendix A: Planning for iSCSI-Based Storage Area Networks (SAN)	38
Physical Server Hosting Hyper-V	38
iSCSI Network Switches	38
Appendix B: Preparing Storage for Your VMs	40
Preparing the Disk for Use as a Passthrough Disk	40
Preparing the Disk for Storing VHDs or VM Files.	41
Appendix C: Glossary	42
Appendix D: References	43

Getting Started With Microsoft® Hyper-V™ Technology

The *Dell Storage Solutions Guide for Microsoft Hyper-V* provides an overview of:

- Storage options available in Hyper-V
- How Dell-supported storage solutions fit into a Hyper-V Deployment
- Best practices associated with solution deployment

The solutions guidance provided in this guide is primarily focused on storage arrays based on their support for key virtualization features, such as high availability and virtual machine migration.

The information in this document assumes that you are familiar with the basic concepts of Hyper-V (refer to *Dell Solutions Overview Guide for Microsoft Hyper-V* at www.dell.com/hyper-v).

For additional information, see *Dell Networking Solutions Guide for Microsoft Hyper-V* and *Dell High Availability Solutions Guide for Microsoft Hyper-V* at www.dell.com/hyper-v.

Understanding Hyper-V Architecture

As described in the *Dell Solutions Overview Guide for Microsoft Hyper-V*, the parent partition (not the hypervisor) manages the I/O devices. To provide virtual machines with access to those devices, Hyper-V supports a high-speed interconnect referred to as the VMBus. Virtual devices, such as network and storage adapters, for each VM communicate with the parent partition through the VMBus. The parent partition receives those requests (through the VSPs) and directs them to the underlying physical devices via the I/O stack of the parent partition (refer to Figure 1). This model requires device drivers for the physical devices to be installed in the parent partition.



NOTE: It is recommended that you download the latest Dell certified drivers available for your system and install them in the parent partition. Using the latest drivers ensures that both the parent partition and VMs are able to fully utilize the underlying physical devices. Download the latest device drivers at support.dell.com.

Figure 1. Hyper-V Architectural Overview

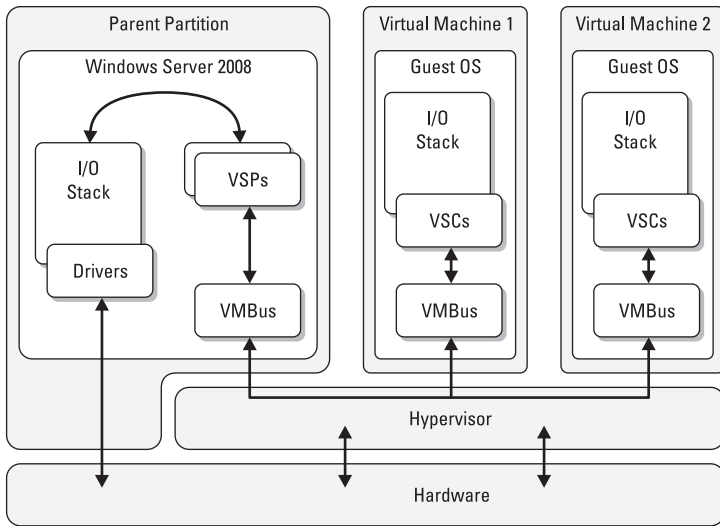

Guest operating systems requires specialized drivers (VSCs) provided by Microsoft in order to access the VMBus. The drivers are specific to the type of device that is presented to the guest operating system through the VM configuration and are installed as a part of the Integration Services that are available for Hyper-V supported guest operating systems.

NOTE: All architecture related information provided in this guide assumes that the guest OS has Integration Services installed.

Advantages of Hyper-V device management model include the following:

- Device specific drivers and utilities created for Windows Server 2008 x64, work and do not require any changes when Hyper-V is enabled.
- The configuration steps required for connectivity to a storage device in the physical instance of Windows Server 2008 (Hyper-V is not enabled) are identical when Hyper-V is enabled and those configuration steps should be carried out in the parent partition.

iSCSI Connections Within the Guest OS

Hyper-V supports iSCSI connections initiated directly from within a guest operating system to an iSCSI storage array. In this configuration, an iSCSI software initiator within the guest OS is connected to an iSCSI storage array. The iSCSI connection and any iSCSI LUNs that are provisioned directly to the guest OS are not visible by the parent partition. The parent partition's involvement is in the management of the networking devices and therefore is not the primary focus of this document. For more information, see "Direct iSCSI Connectivity Within Guest OS" on page 34.

Storage Options for Virtual Machines (VMs) in Hyper-V



NOTE: The figures in this section do not represent best practices and are only meant to depict possible configurations available with Hyper-V.

There are three major categories that must be considered for each disk that will be presented to a VM. The options within each of the categories have a unique set of attributes that determine critical factors such as compatibility, performance, and availability:

DISK TYPE — The type of disk the VM utilizes.

- Virtual hard disk (VHD)
- Passthrough disk

DISK LOCATION — The physical location where the disk will be housed.

- Internal storage
- External storage
- SMB/CIFS share

DISK INTERFACE — Based on the type of virtual controller the disk is attached to, the disk will be presented to the VM as the desired disk interface.

- IDE
- SCSI

Disk Type

Virtual Hard Disk

A VHD is a file that resides on a formatted partition that the parent partition has access to (see Figure 2). When presented to a VM, this file appears to the guest OS as a hard disk with a set of raw blocks. The guest OS can utilize the VHD just as it would a physical disk.

Figure 2. VMs Using VHD

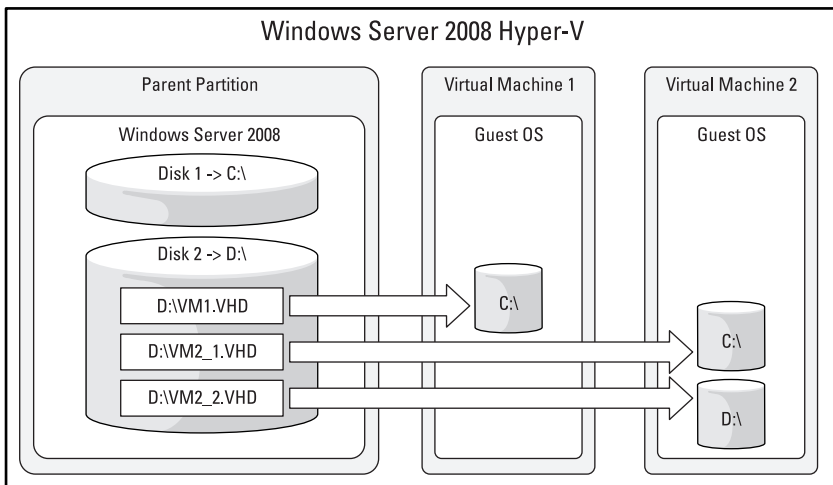

Three types of VHDs (defined at VHD creation) are supported:

DYNAMICALLY EXPANDING — The VHD file grows as data is stored to the disk with a maximum size not exceeding the size specified during creation. Dynamically expanding is the default option when creating a new virtual machine using the **New Virtual Machine Wizard** in Hyper-V Manager.

FIXED SIZE — The VHD file uses the full amount of space specified during creation.

DIFFERENCING — The VHD file exists as a child disk in a parent/child relationship with an existing VHD. The parent VHD is left intact and changes that occur are stored on the child (differencing) VHD.



NOTE: For production environments, a fixed-size VHD is recommended based on increased performance over dynamically-expanding and differencing disks.

Passthrough Disk

A passthrough disk is a physical disk mapped directly to a VM (see Figure 3). To the parent partition, the disk is in an offline state and direct read/write access to the disk is not available. I/O requests from the VM are **passed through** the parent partition to the disk. With the parent partition free from managing the disk, additional CPU cycles are provided for virtual machine processing. When mapped to a passthrough disk, the guest OS has direct access to the raw blocks of the physical storage device.

Figure 3. VMs Using Passthrough Disk

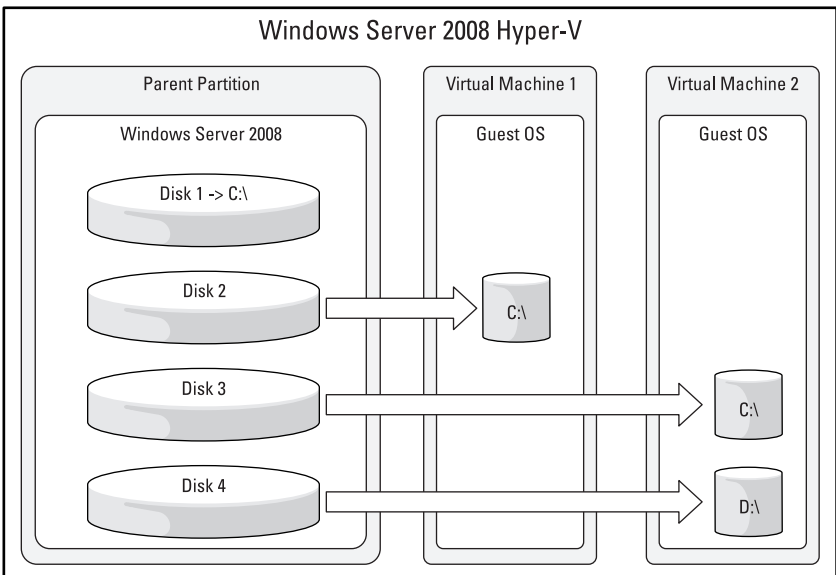

Considerations When Utilizing Passthrough Disks

- Hyper-V does not restrict multiple VMs from selecting the same passthrough disk during VM configuration. If the same passthrough disk is selected by multiple VMs, data may be inadvertently overwritten. Ensure that you select the appropriate disk during configuration.

- Hyper-V does not restrict VMs from selecting disks that have been made a clustered resource as a passthrough disk. If disks that have been made a clustered resource are selected as passthrough disks for other VMs, data may be inadvertently overwritten. Ensure that you select the appropriate disk during configuration.
- A disk that is selected as a passthrough disk for a VM remains in the offline state in the parent partition; however, if the disk is accidentally placed in the online state, data corruption/loss may occur.

Disk Type Summary

Table 1. Disk Type Summary

Disk Type	Advantages	Disadvantages
VHD	<ul style="list-style-type: none"> • Hyper-V VSS Support for host-based backup of VMs • Greater portability - exported VM can be easily copied/moved to another location • Multiple VHDs may reside on a single physical disk • Supports VM checkpoints 	<ul style="list-style-type: none"> • VHD size is limited to less than 2 TB • Additional processor resources are required to manage I/O requests to the VHD
Passthrough	<ul style="list-style-type: none"> • Supports greater than 2-TB LUNs • Offers slightly higher performance than VHDs 	<ul style="list-style-type: none"> • Does not support Hyper-V VSS for host-based backup of VMs • Does not support Hyper-V VM checkpoints • Lacks portability of VHD (no export) • If booting from a passthrough disk, an additional storage location is required for the VM files (XML, BIN, VSV)

Disk Location

When determining VHD and/or passthrough disk location for VM(s), the following options are available:

- Internal storage
- External storage
- SMB/CIFS Share

Internal Storage

Internal storage encompasses disks that reside within the server chassis. Internal disks can be presented directly to the server or they can be managed by a RAID controller to provide disk aggregation and fault tolerance. Because the boot volume has a file system on it, using it as a passthrough disk is not an option. VHDs can be placed on the boot volume, however this is not a recommended configuration. If internal storage is used, additional disks within the system should be utilized as either passthrough disks or formatted for storage of VHDs.

External Storage

External storage encompasses disks that do not reside within the server chassis. External disks can be used as either passthrough disks or VHDs while offering storage expansion and providing additional feature support in Hyper-V. There are two major categories of external storage:

HOST-BASED RAID CONTROLLER WITH EXTERNAL STORAGE ENCLOSURE —

Provides additional storage for a server through an internal RAID controller and an external storage enclosure (commonly referred to as a JBOD). For Hyper-V, using a host-based RAID controller with external storage enclosure does not provide additional feature support over internal storage.

STORAGE ARRAYS — Contains iSCSI, FC, and SAS arrays that have built-in storage controllers required for supporting shared storage between multiple servers (see Figure 4). With support for shared storage, storage arrays provide the potential to support a Microsoft Failover Cluster. The failover cluster is utilized by Hyper-V to support highly available virtual machines and virtual machine migration (see the *Dell High Availability Solutions Guide for Microsoft Hyper-V* at www.dell.com/hyper-v).

Figure 4. Storage Array (Single Server Configuration)

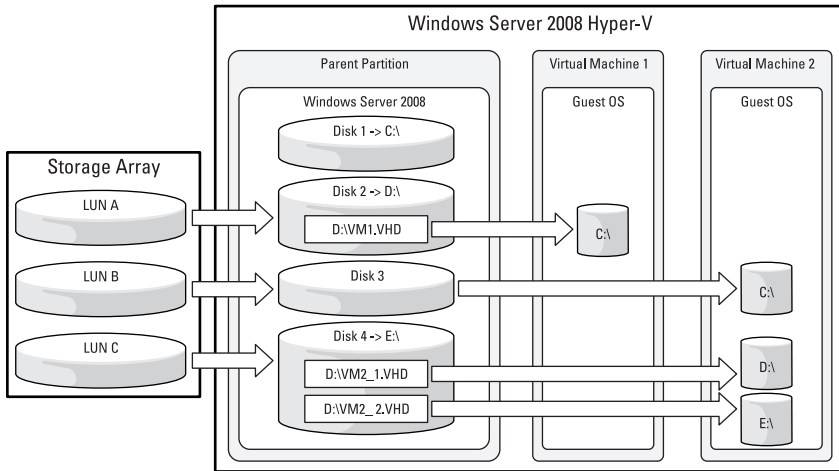

SMB/CIFS Share

In addition to supporting a VHD on a disk managed by the parent partition, Hyper-V also supports VHDs on a SMB/CIFS share; however, the use of SMB/CIFS shares is beyond the scope of this document. For more information see the Microsoft Hyper-V documentation or the *Dell High Availability Solutions Guide for Microsoft Hyper-V* at www.dell.com/hyper-v.

Disk Location Summary

Table 2. Disk Location Summary

Type	Advantages	Disadvantages
Internal storage	Easy configuration and management for entry-level configurations.	Lacks support for HA VMs and VM Quick Migration.
Host-based RAID with external enclosure	Provides additional storage capacity for the server.	Lacks support for HA VMs and VM Quick Migration.

Type	Advantages	Disadvantages
Storage array	<ul style="list-style-type: none"> • Support for HA VMs and VM Quick Migration. • Provides additional storage capacity for the server. 	
SMB/CIFS share	<ul style="list-style-type: none"> • Support for HA VMs and VM Quick Migration. • Provides additional storage capacity for the server. 	<ul style="list-style-type: none"> • Does not support passthrough disks. • Relatively lower performance

Disk Interface

After the disk type and storage location have been determined, the next step is to determine what type of virtual storage controller the disk will reside on. Hyper-V supports both IDE and SCSI controllers for VHD and passthrough disks. The controller type selected will determine the disk interface type that the guest OS will see. This disk interface type (IDE or SCSI) is completely independent of the physical disk technology. This concept is shown below in Figure 5 with a fibre channel storage array. All VMs must boot from an IDE device. Additional disks may reside on either an IDE or SCSI controller.

Figure 5. Disk Interface (With an Attached Fibre Channel Storage Array)

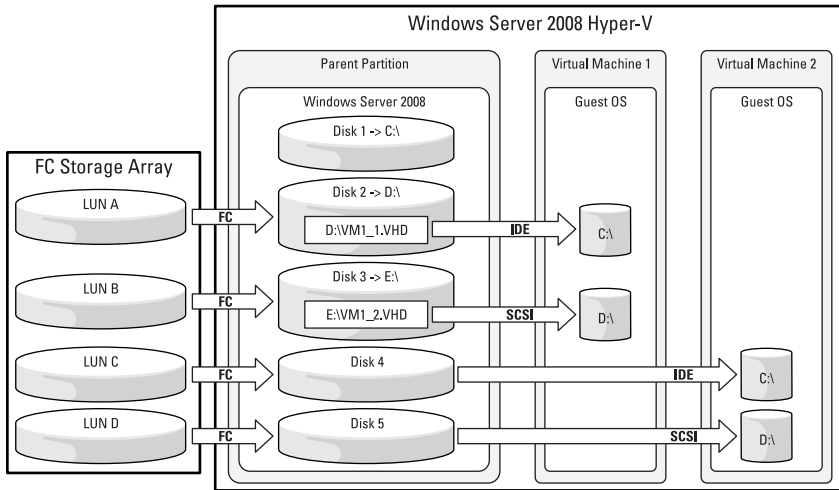

Integration Services

By default, a guest OS only supports emulated IDE devices. Emulated IDE devices typically require a large amount of processor overhead to handle the device emulation and do not utilize the high-speed VMBus. To utilize the VMBus and therefore increase I/O performance, Hyper-V supports synthetic SCSI devices and an enhanced mode for IDE devices through the installation of Integration Services within the guest OS. For existing IDE emulated devices, a filter driver is loaded when Integration Services is installed to allow for use of the VMBus. SCSI devices are only supported as synthetic devices and therefore require that Integration Services be installed. In addition, SCSI device support is guest OS specific.

The following guest operating systems support SCSI devices:

- Windows Server 2008 (x64)
- Windows Server 2008 (x86)
- Windows Server 2003 (x64) SP2
- Windows Server 2003 (x86) SP2
- SLES 10 (x64) SP2
- SLES 10 (x86) SP2

- Windows Vista (x64) SP1
- Windows XP Professional (x86) SP2-SP3
- Windows XP Professional (x64) SP2

For a current list of guest operating systems that support synthetic SCSI devices, refer to the *Hyper-V Planning and Deployment Guide* available at www.microsoft.com/downloads.

Disk Interface Summary

Table 3. Disk Interface Summary

IDE	<ul style="list-style-type: none"> • All virtual machines must boot from an IDE device. • A maximum of four IDE devices are available for each virtual machine. • Virtual DVD drives can only be created as an IDE device.
SCSI	<ul style="list-style-type: none"> • Preferred choice for all data volumes based on I/O performance. • Requires that the guest OS has Integration Services installed. • A maximum of four SCSI controllers are available for each virtual machine. • Limit of 64 SCSI devices per SCSI controller. • A subset of the Hyper-V supported operating systems support SCSI devices.

Understanding the Storage I/O Path

The storage I/O path is the path that a disk I/O request generated by an application within a VM's guest OS must take to a storage device. In general, there are two distinct storage configurations based on the selected disk type (VHD or passthrough), each with a unique storage I/O path.

VHD

The disk I/O request flows from the guest application through the storage stack of the guest OS to the file system of the parent partition. The read or write request is executed on the file containing the VHD, and then is routed through the remainder of the storage stack onto the physical device.

Figure 6. VHD I/O Path

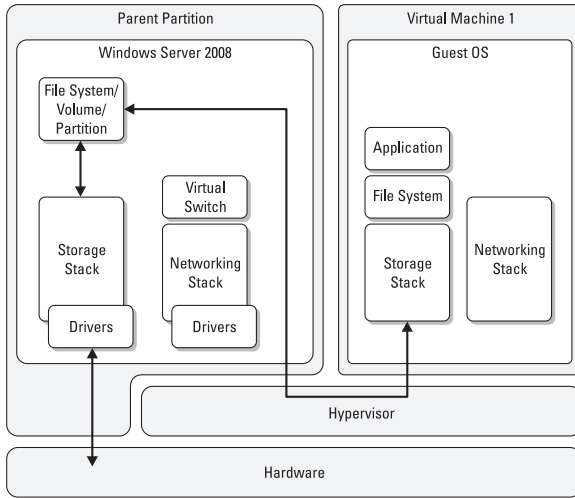

Passthrough

The disk I/O request flows from the guest application through the storage stack of the guest OS and into the parent partition. Unlike VHDs that have a file system, volume, and disk partition in the parent partition, the passthrough disk is a raw device. Therefore, the I/O request is routed directly into the remainder of the parent partition's storage stack and onto the physical device.

Figure 7. Passthrough I/O Path

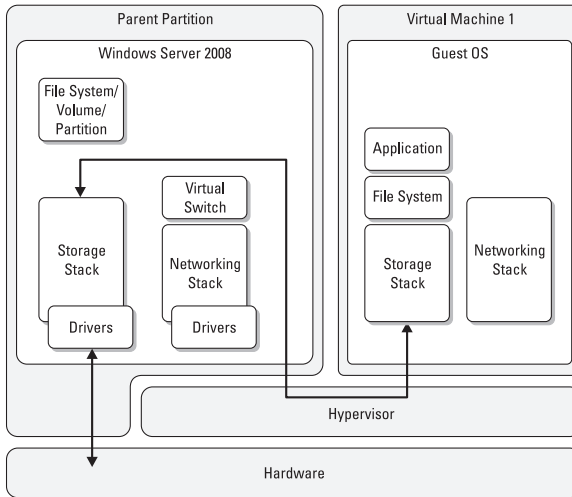

Dell Supported Storage Arrays

Storage arrays provide the capability to support Microsoft Failover Clusters and in turn provide support for highly available virtual machines and virtual machine migration. This section provides information on supported Dell PowerVault™, Dell EqualLogic™, and Dell|EMC™ arrays, an overview of configuration steps, and associated best practices.

Table 4. Supported Storage Arrays

Dell EqualLogic	PS Series Arrays
Dell EMC	CX4 Series Arrays
	CX3 Series Arrays
	CX300/500/700
	AX4-5i/AX4-5f
	AX150/AX150i
Dell PowerVault	MD3000/MD3000i

iSCSI Arrays

In addition to supporting the features described for all storage arrays, iSCSI arrays also provide support for booting from an iSCSI SAN (BFI) where the Windows 2008 Server files, including the Hyper-V additions, reside on a disk on the iSCSI array. For more information on BFI, refer to the whitepaper, *Dell PowerEdge™ Systems Instructions to Perform Boot from iSCSI for Dell Storage Arrays* at support.dell.com/support/edocs/network/BFI.

The following considerations should be made when implementing BFI:

- Hyper-V restricts virtual switches from being created on the adapters used for BFI.
- BFI is not currently supported for clustered hosts.
- BFI is not currently supported with VLANs.

Planning your network configuration is a critical element of successful iSCSI deployment with Hyper-V. For best practices refer to "Appendix A: Planning for iSCSI-Based Storage Area Networks (SAN)" on page 38.



Dell EqualLogic PS Series

The Dell EqualLogic PS series of iSCSI storage arrays offers high performance, reliability, intelligent automation, and seamless virtualization of a single pool of storage to enable simplified enterprise storage deployment and management. EqualLogic PS series arrays are capable of supporting up to 2048 iSCSI connections per group of PS series arrays.

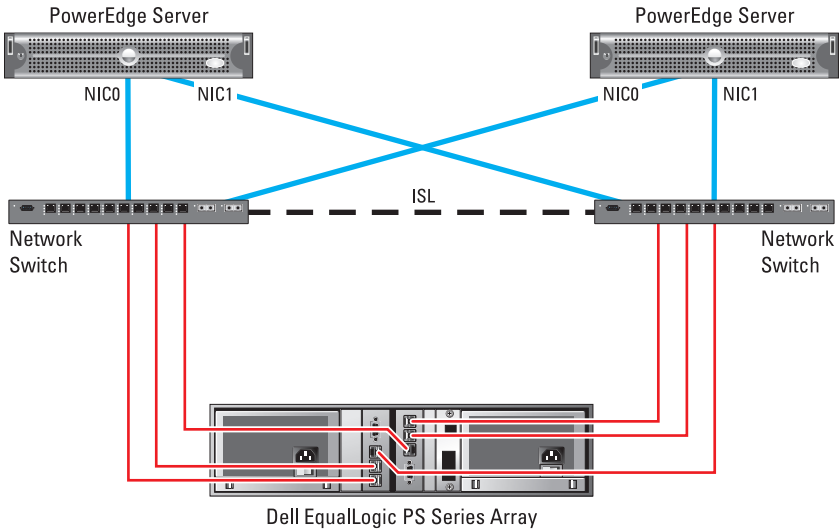
Figure 8. Dell EqualLogic PS Series (Single Array)



To provide VMs with access to storage residing on a Dell EqualLogic PS series array:

- 1 Confirm that your planned configuration is supported (see www.equallogic.com/resources/technicaldocumentsview.aspx).
 -  **NOTE:** The minimum required host software version is HIT 3.1.1. The recommended array firmware version is 4.0.1 or later.
- 2 Establish connectivity between the server and the array, and then provision LUNs to the server (see www.equallogic.com/resources/technicaldocumentsview.aspx).
 -  **NOTE:** Follow the steps for Windows Server 2008 within the documentation. The configuration and software installation detailed in the guide is carried out in the parent partition.
 -  **NOTE:** Dell highly recommends to run the executable file 'EqISetupUtil.exe' within the parent partition to update the disk and iSCSI timeout values in registry. By default this file is located in `c:\Program Files\EqualLogic\bin` after installation of the Host Integration Tools kit within the parent partition. In addition, this file should be executed on all VMs running either Windows Server 2003 or Windows Server 2008.

Best practices during configuration:

- For information on appropriately sizing the LUNs, see "Sizing Storage for Your VM" on page 30.
 - LUNs that store virtual machine data should reside on a fault tolerant RAID group.
 - Each virtual machine should have its own unique set of LUNs that contain the virtual machine files and virtual machine hard drives.
- 3** Provide virtual machines with the provisioned storage as either passthrough disks or format the disks and place VHDs on the formatted partition (see "Appendix B: Preparing Storage for Your VMs" on page 40).

Dell PowerVault MD3000i

The PowerVault MD3000i is a modular disk storage array capable of supporting up to sixteen highly available hosts. The MD3000i can contain up to fifteen 3.5-inch SAS or SATA disk drives in a single 3U rack enclosure and is expandable by adding up to two additional expansion enclosures for a total of 45 drives. The entire array subsystem is managed from the Modular Disk Storage Manager (MDSM), a single software application that streamlines the management and maintenance of storage as it scales.

Figure 9. Dell PowerVault MD3000i

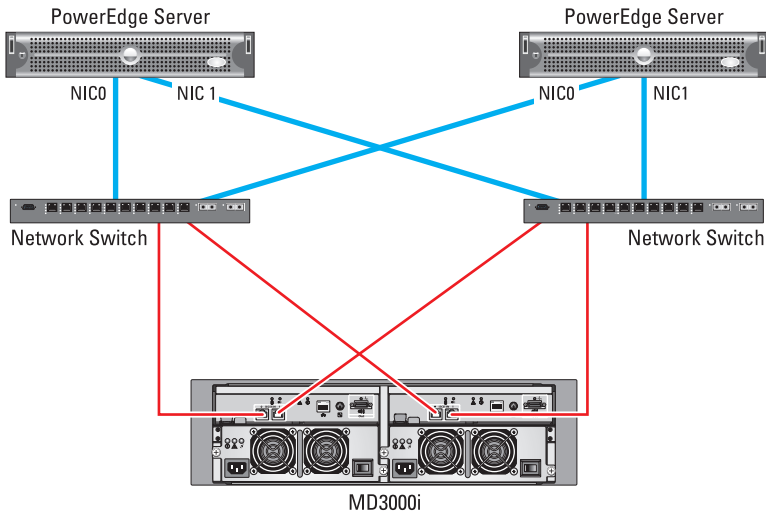

To provide VMs with access to storage residing on a Dell PowerVault MD3000i:

- 1 Confirm that your planned configuration is supported (see the *MD3000i Support Matrix* at support.dell.com/support/edocs/systems/md3000i).



NOTE: The minimum versions required for support are array firmware version 06.70.17.60 and host software Resource CD version A04 (contains MPIO DSM v01.02.36.19).

- 2 Establish connectivity between the server and the MD3000i (see the *Dell PowerVault Modular Disk 3000i Systems Installation Guide* at support.dell.com/support/edocs/systems/md3000i).



NOTE: Follow the steps for Windows Server 2008 within the documentation. The configuration and software installation detailed in the guide is carried out in the parent partition.

If a version earlier than A04 of the MD3000i Resource CD installation media was utilized, you must update the disk timeout values manually. These steps are not required for version A04 or later.

To confirm the settings within the parent partition, perform the following steps:



NOTICE: Always create a backup of the registry before you make any changes to the registry. For information on backing up the registry, see support.microsoft.com/kb/322756.

- a Type `regedit` at the command prompt, and then press <Enter>. The **Registry Editor** window appears.

- b In the left pane of the **Registry Editor** window, locate the following registry path:

Computer\HKEY_LOCAL_MACHINE\SYSTEM\CurrentControlSet\Services\Disk\TimeOutValue.

- c In the right pane of the **Registry Editor** window, verify that the key value is set to 0x000000a0 (160).

- d In the left pane of the **Registry Editor** window, locate the following registry path:

Computer\HKEY_LOCAL_MACHINE\SYSTEM\CurrentControlSet\Control\Class\{4D36E97B-E325-11CE-BFC1-08002BE10318}\xxxx\Parameters\LinkDownTime



NOTE: xxxx represents a four-digit string. Multiple entries may be present; however, only one entry will contain the Parameters\LinkDownTime path.

- e In the right pane of the **Registry Editor** window, verify that the key value is set to 0x00000090 (144).
 - f Close the **Registry Editor** window and reboot the system.
- 3** Register the server in MDSM and provision LUNs to the server (see the *Dell PowerVault Modular Disk Storage Manager User's Guide* at support.dell.com/support/edocs/systems/md3000i).

Best practices during configuration:

- For information on appropriately sizing the LUNs, see "Sizing Storage for Your VM" on page 30.
 - LUNs that store virtual machine data should reside on a fault tolerant disk group.
 - Each virtual machine should have its own unique set of LUNs that contain the virtual machine files and virtual machine hard drives.
- 4** Provide virtual machines with the provisioned storage as either passthrough disks or format the disks and place VHDs on the formatted partition (see "Appendix B: Preparing Storage for Your VMs" on page 40).
- 5** After creating and starting each VM, update SCSI timeout values within the guest OS.



NOTE: Failure to update the SCSI timeout values within the guest OS may result in unexpected behavior such as guest OS reboots or freezes.

For VMs running a Microsoft operating system, perform the following steps:



NOTICE: Always create a backup of the registry before you make any changes to the registry. For information on backing up the registry, see support.microsoft.com/kb/322756.

- a Type `regedit` at the command prompt, and then press <Enter>. The **Registry Editor** window appears.
- b In the left pane of the **Registry Editor** window, locate the following registry path:
`Computer\HKEY_LOCAL_MACHINE\SYSTEM\CurrentControlSet\Services\disk\TimeOutValue`

- c** In the right pane of the **Registry Editor** window, verify that the key value is set to 0x000000a0 (160).
- d** Close the **Registry Editor** window and reboot the VM.

For VMs running a Linux operating system with the 2.6 kernel, perform the following steps:

- a** Create a new udev rule by creating a file with the name **96-dell-sto.rules** at `/etc/udev/rules.d/`.
- b** Type the following text (case sensitive) within the file and save the file:

```
KERNEL=="sd* [!0-9] ", ACTION=="add", RUN+=  
"/bin/sh -c 'echo 200 >  
/sys$DEVPATH/device/timeout' "
```

- c** Reboot the VM.

Dell|EMC CLARiiON Arrays

The Dell|EMC CLARiiON™ series of arrays provides high performance, availability, and advanced management features. In addition, the latest generation CX3 and CX4 series supports both iSCSI and FC connectivity on one array. The number of hosts supported varies with by model, refer to the product documentation available on powerlink.emc.com for more information.

Figure 10. Dell|EMC CLARiON (iSCSI Array)

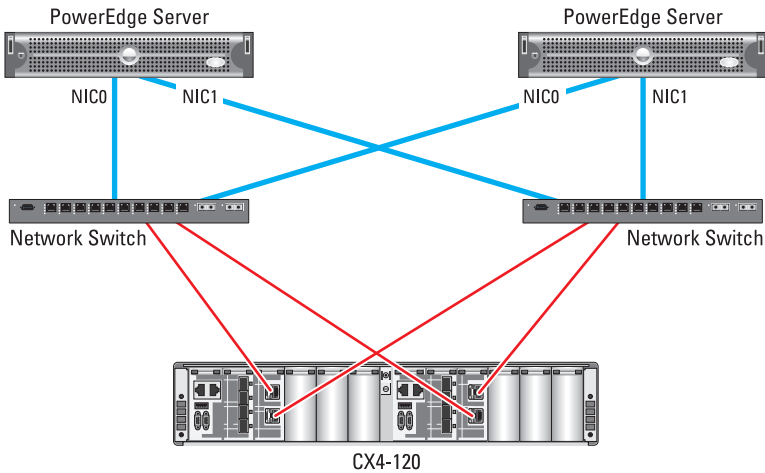

To provide VMs with access to storage residing on a Dell|EMC CLARiON array:

- 1 Confirm that your planned configuration is supported (see the *EMC Support Matrix* and *Virtualization Server Support* at elabnavigator.emc.com).



NOTE: The following minimum versions are required for support:

Array:

- CX4 Series: FLARE 28
- CX3 Series: FLARE 26
- AX4-5i: FLARE 23
- AX150i: FLARE 20

Host software:

- PowerPath 5.2

- 2 Establish connectivity between the server and the array, and then provision LUNs to the server (see the user customized documentation available at powerlink.emc.com). This will include installation of PowerPath and Navisphere Agent within the parent partition.

 **NOTE:** Follow the steps for Windows Server 2008 within the documentation. The configuration and software installation detailed in the guide should be carried out in the parent partition.

Best practices during configuration:

- For information on appropriately sizing the LUNs, see "Sizing Storage for Your VM" on page 30.
 - LUNs that store virtual machine data should reside on a fault tolerant RAID group.
 - Each virtual machine should have its own unique set of LUNs that contain the virtual machine files and virtual machine hard drives.
- 3** Provide virtual machines with the provisioned storage as either passthrough disks or format the disks and place VHDs on the formatted partition (see "Appendix B: Preparing Storage for Your VMs" on page 40).

Fibre Channel Arrays

Dell|EMC CLARiiON Arrays

The Dell|EMC CLARiiON series of arrays provides high performance, availability, and advanced management features. In addition, the latest generation CX3 and CX4 series supports both iSCSI and FC connectivity on one array.

Figure 11. Dell|EMC CLARiiON (Fibre Channel Array)

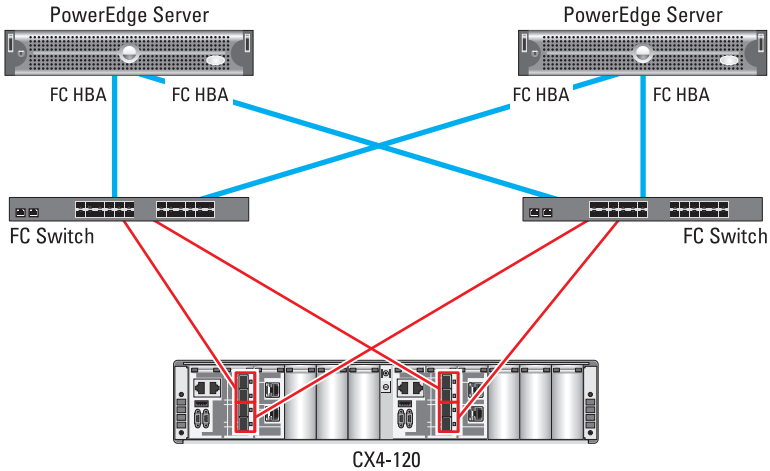

To provide VMs with access to storage residing on a Dell |EMC CLARiiON array:

- 1 Confirm that your planned configuration is supported (see the *EMC Support Matrix* and *Virtualization Server Support* at elabnavigator.emc.com).

NOTE: The following minimum versions are required for support:

Array:

- CX4 Series: FLARE 28
- CX3 Series: FLARE 26
- CX300/500/700: FLARE 26
- AX4-5f: FLARE 23
- AX150: FLARE 20

Host software:

- PowerPath 5.2

- 2 Establish connectivity between the server and the array, and then provision LUNs to the server (see the user customized documentation available at powerlink.emc.com).



NOTE: Follow the steps for Windows Server 2008 within the documentation. The configuration and software installation detailed in the guide should be carried out in the parent partition.

Best practices during configuration:

- For information on appropriately sizing the LUNs, see "Sizing Storage for Your VM" on page 30.
 - LUNs that store virtual machine data should reside on a fault tolerant RAID group.
 - Each virtual machine should have its own unique set of LUNs that contain the virtual machine files and virtual machine hard drives.
- 3** Provide virtual machines with the provisioned storage as either passthrough disks or format the disks and place VHDs on the formatted partition (see "Appendix B: Preparing Storage for Your VMs" on page 40).

SAS Arrays

Dell PowerVault MD3000

The PowerVault MD3000 is a modular disk storage array capable of housing up to fifteen 3.5-inch SAS or SATA disk drives in a single 3U rack enclosure and is expandable by adding up to two additional expansion enclosures for a total of 45 drives. In the recommended configuration, the MD3000 can support up to two hosts (see Figure 12). The entire array subsystem is managed from the Modular Disk Storage Manager (MDSM), a single software application that streamlines the management and maintenance of storage as it scales.

Figure 12. Dell PowerVault MD3000

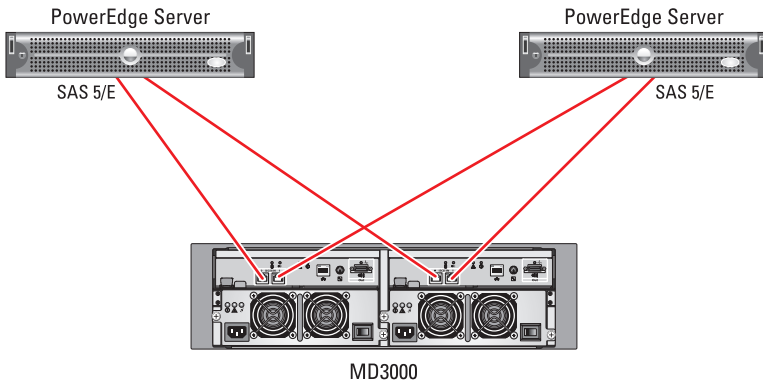

To provide VMs with access to storage residing on a MD3000:

- 1 Confirm that your planned configuration is supported (see the MD3000 Support Matrix at support.dell.com/support/edocs/systems/md3000).

 **NOTE:** The minimum versions required for support are array firmware version 06.70.17.60 and host software Resource CD version A05 (contains MPIO DSM v01.02.36.19).

- 2 Establish connectivity between the server and the MD3000 (see the *Dell PowerVault Modular Disk 3000 Systems Installation Guide* at support.dell.com/support/edocs/systems/md3000).

 **NOTE:** Follow the steps for Windows Server 2008 within the documentation. The configuration and software installation detailed in the guide should be carried out in the parent partition.

- 3 Register the server in MDSM and provision LUNs to the server (see the *Dell PowerVault Modular Disk Storage Manager User's Guide* at support.dell.com/support/edocs/systems/md3000).

 **NOTE:** Follow the steps for Windows Server 2008 within the documentation. The configuration and software installation detailed in the guide should be carried out in the parent partition.

Best practices during configuration:

- For information on appropriately sizing the LUNs, see "Sizing Storage for Your VM" on page 30.

- LUNs that store virtual machine data should reside on a fault tolerant disk group.
 - Each virtual machine should have its own unique set of LUNs that contain the virtual machine files and virtual machine hard drives.
- 4 Provide virtual machines with the provisioned storage as either passthrough disks or format the disks and place VHDs on the formatted partition (see "Appendix B: Preparing Storage for Your VMs" on page 40).
 - 5 After creating and starting each VM, update SCSI timeout values within the guest OS.



NOTE: Failure to update the SCSI timeout values within the guest OS may result in unexpected behavior such as guest OS reboots or freezes.

For VMs running a Microsoft operating system, perform the following steps:

a Type `regedit` at the command prompt, and then press <Enter>. The **Registry Editor** window appears.

b In the left pane of the **Registry Editor** window, locate the following registry path:

```
Computer\HKEY_LOCAL_MACHINE\SYSTEM\CurrentControlSet
\Services\disk\TimeOutValue
```

c In the right pane of the **Registry Editor** window, verify that the key value is set to `0x000000a0` (160).

d Close the **Registry Editor** window and reboot the VM.

For VMs running a Linux operating system with the 2.6 kernel, perform the following steps:

a Create a new udev rule by creating a file with the name **96-dell-sto.rules** at `/etc/udev/rules.d/`.

b Type the following text (case sensitive) within the file and save the file:

```
KERNEL=="sd* [!0-9] ", ACTION=="add", RUN+=
"/bin/sh -c 'echo 200 >
/sys$DEVPATH/device/timeout' "
```

c Reboot the VM.

Additional Dell Supported Storage Solutions

Internal Storage

Any Dell internal storage device that is supported by Windows Server 2008 x64 is also supported by Hyper-V. Refer to the device documentation to confirm Windows Server 2008 x64 support.

Host-Based RAID With External Enclosures

Any host-based RAID controller (with external enclosure) that is supported by Windows Server 2008 x64 is also supported by Hyper-V. Refer to the device documentation to confirm Windows Server 2008 x64 support details.

Table 5. Supported External Enclosures

Dell PowerVault	MD1000
	MD1120

Figure 13. Host-Based RAID With a Single External Enclosure

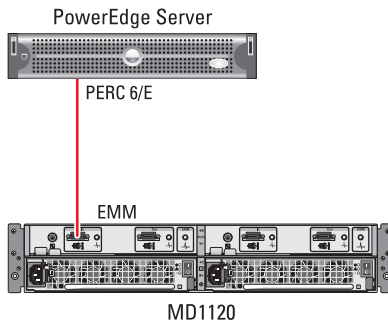

Sizing Storage for Your VM

NOTE: The recommendations provided in this section are based upon best practices for a production environment. If you plan to place all of your files on internal storage, the recommendations may not be appropriate for your needs.

The information in this section is meant to help you understand the space that will be utilized for your virtual machines. The worksheet below can be utilized for each VM in your solution.

Component	Notes
Guest OS Base Image Size: _____	The guest OS will reside on the boot IDE device of the VM.
Guest OS Page File Size: _____	Recommended size is 1.5 times the amount of RAM allocated to the VM.
VM Files: _____	Includes VM configuration, device state, and memory (XML, VSV, and BIN) files. The size allocated should be 200 MB plus the size of VM memory.
Guest OS Additional Storage: _____	Additional storage is required for applications, application data, log files, etc. It is recommended that you place the data drives on a dedicated LUN and present them to the VM as a synthetic SCSI device that likewise resides on its own SCSI controller.

When determining the appropriate storage to provision for a VM, there are two major factors to consider:

- In which category of I/O utilization is each component classified (light, medium, or heavy)?

For your purposes, placing multiple components on the same disk may be necessary; however, if your VM is I/O intensive, the components that are accessed frequently (log files, page file, etc.) should reside on their own unique LUN. The disks should then be attached to their own synthetic SCSI controller. Because Hyper-V supports a maximum of four synthetic SCSI controllers, some synthetic SCSI controllers may require more than one SCSI disk attached to them. Careful planning is required for I/O intense VMs to balance the I/O utilization across the controllers.

- Does the storage space required on a single disk exceed 2 TB?

VHD size is limited to less than 2 TB. If this is a factor in your configuration, a passthrough disk may be more appropriate or the data must be split across multiple VHDs.

Sizing for VHDs

Each LUN should be sized to support the target VHD. If the VM files will be stored on the LUN, then that must be taken into account as well. To avoid warning messages generated by the parent partition concerning disk running out of capacity, the LUN should have an additional 200MB allocated and this should be left as empty space on the volume.

NOTE: For increased performance, fixed disk VHDs are recommended. It is also recommended that each VHD be placed on its own LUN (see Figure 14).

Figure 14. VHDs With Dedicated LUNs.

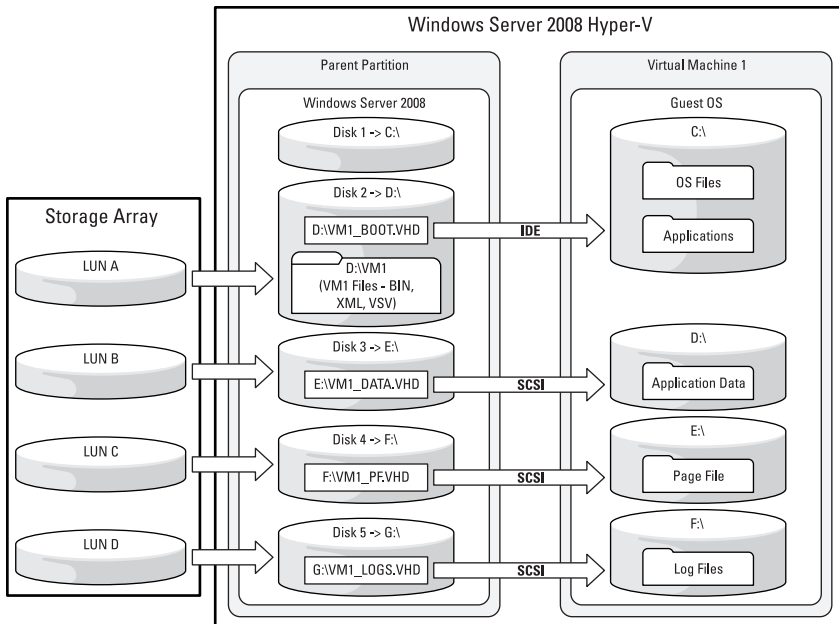

VM checkpoints (referred to as snapshots in Hyper-V Manager) reduce I/O performance and are therefore not recommended for production environments. If checkpoints are utilized, additional space requirements for the checkpoints must be taken into consideration. All checkpoint files, including the differencing disks and virtual machine state files (memory and configuration), are stored in a directory available to the parent partition. By default, the directory is on the same partition as the boot VHD. When a

checkpoint is taken, a differencing disk is created for all VHDs assigned to the VM. The disk space required for the checkpoint files depends upon the frequency checkpoints are created, the rate of change of data, and the amount of memory assigned to the virtual machine.

Sizing for Passthrough Disks

The sizing requirements for passthrough disks are similar to VHDs with the following differences:

- A separate NTFS partition must be available for the parent partition to utilize for placement of the VM configuration files. The partition/volume should not be shared with other data or VMs.
- The parent partition does not manage the disk; therefore, allocating additional disk space to avoid error messages is not required.
- Additional storage for VM checkpoints is not required (passthrough disks do not support the use of checkpoints).

Figure 15. Passthrough Disk

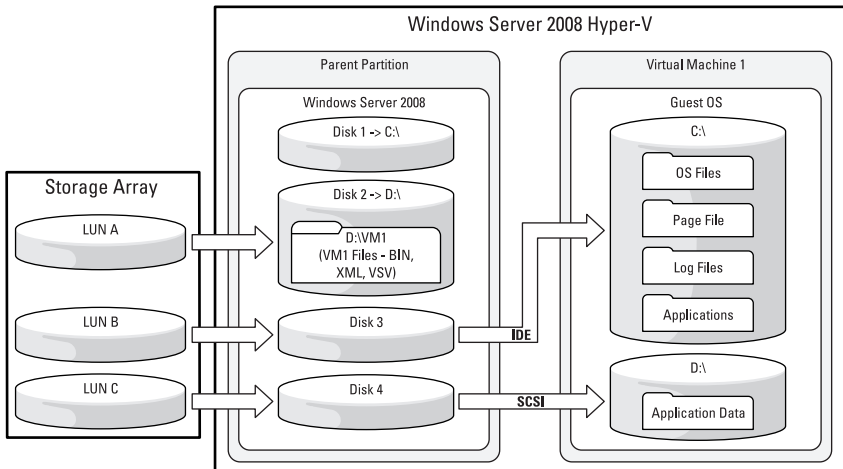

Direct iSCSI Connectivity Within Guest OS

To successfully create direct iSCSI connections within the guest OS, the guest OS must:

- Support an iSCSI software initiator.
- Be supported by the storage device.
- Have the required storage device specific drivers and software installed.

Setup and configuration of the iSCSI connection within the guest OS is the same as that for a physical server running the same OS. Refer to the storage device documentation for setup and configuration information.

Figure 16. Direct iSCSI Connectivity Within Guest OS

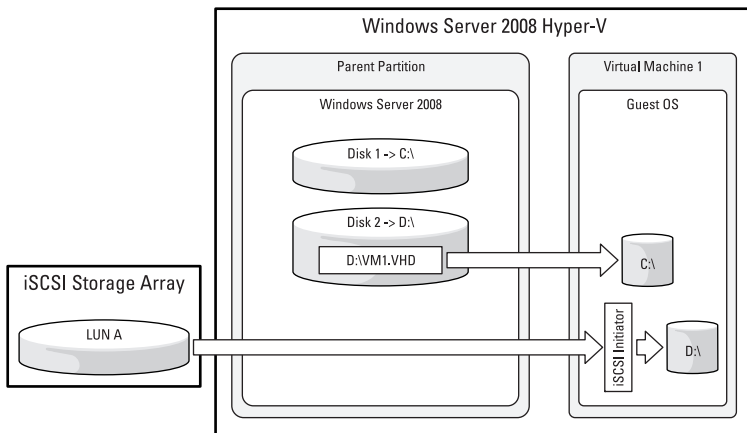

iSCSI Connections from Both the Parent Partition and Guest OS

Because Hyper-V does not support Boot from iSCSI SAN (BFi) for VMs, iSCSI direct connections only apply to data volumes. To host all the files of a VM on iSCSI LUNs, you will need to have iSCSI connections from both the parent (to host the VMs boot disk) and guest OS (to host the VMs data disks). Using a combination of connections provides a great deal of flexibility for configuring iSCSI connections to meet each VM's storage needs.

Figure 17. iSCSI Connections From the Parent Partition and Guest OS

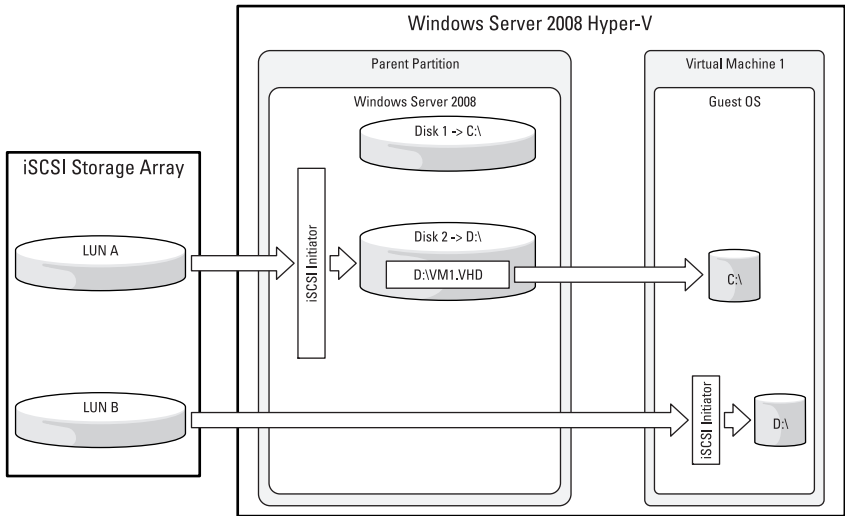

Direct iSCSI Connection Storage I/O Path

The disk I/O request flows from the guest application through the storage stack of the guest OS. The request is then placed into an iSCSI packet(s) and is transmitted through the networking stack of the guest OS, the networking stack of the parent partition, and to the iSCSI storage array.

Figure 18. iSCSI Direct From Guest OS I/O Path

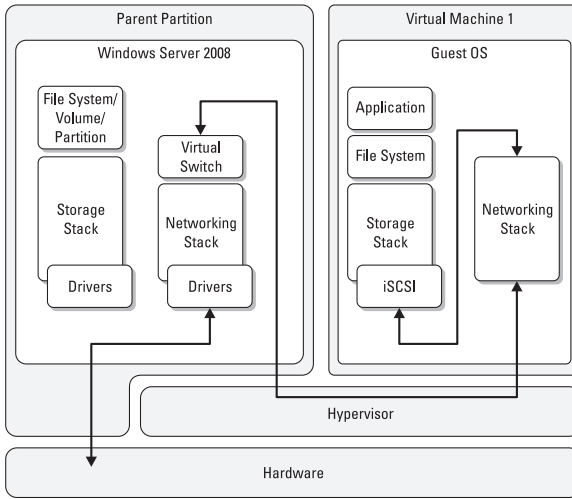

iSCSI Connection Summary

Table 6. iSCSI Connection

iSCSI Initiator Running In	Advantages	Disadvantages
Parent	<ul style="list-style-type: none"> • Can present multiple LUNs to VMs over a single iSCSI connection • Utilizes one host connection on the storage array* • Leverages jumbo frame support (jumbo frames should be enabled on the physical NIC in the parent partition) 	<ul style="list-style-type: none"> • Reduced isolation of LUNs (all VMs and the parent partition potentially have read/write) • Does not support <i>hot add</i> of additional disks for the VM (to provide additional disks to the VM, the VM must be taken offline)

iSCSI Initiator Running In	Advantages <i>(continued)</i>	Disadvantages <i>(continued)</i>
Guest	<ul style="list-style-type: none"> • Imported/exported VM does not require modification of storage array settings for iSCSI direct LUNs • In physical to virtual (P2V) conversions, reconfiguration after conversion of the iSCSI initiator or target is not required • Allows <i>hot add</i> of additional disks for the VMs 	<ul style="list-style-type: none"> • Only supported on data volumes • Each Guest OS that connects reduces the number of host connections available by the storage array* • VSS host-based snapshots (initiated in the parent partition) do not capture the volumes on iSCSI LUNs

* The Dell supported storage arrays limit the number hosts connected to an array or the number of iSCSI connections to an array. For example, the MD3000i allows up to 16 hosts to attach to a single system. Refer to the storage array specific documentation for additional information.

Appendix A: Planning for iSCSI-Based Storage Area Networks (SAN)

Use the following *best practices* to enhance performance and high availability in the Hyper-V server, the networking environment, and iSCSI traffic.

Physical Server Hosting Hyper-V

- Use a minimum of two network adapters for high availability. If possible, the adapters selected should not reside on the same physical adapter. For example, one adapter may be from the LAN on motherboard (LOM) and the other may be from an add-in network card.
- Configure multipathing for high availability. For more information, see the whitepaper *Creating Multipath Connections to Dell iSCSI Storage Arrays* at www.dell.com/TechCenter.



NOTE: Multipathing is provided through MPIO. Teaming of network adapters that will be utilized for iSCSI traffic is not supported.

- Use dedicated NICs for iSCSI traffic. NICs should not be shared with other network traffic (management, general network traffic, etc).

To provide a sufficient level of security and segregation, consider isolating iSCSI infrastructure on a dedicated storage network (or separating the shared environment with VLANs), as well as applying authentication and encryption methods, such as CHAP and IPsec.

- For network adapters that are utilized for iSCSI traffic:
 - Do not create virtual networks on the network adapters
 - Enable flow control
 - Enable jumbo frames

iSCSI Network Switches

- Connect iSCSI switches in a reliable and redundant manner. Use multiple cables and switch trunking to create a high-bandwidth link between multiple switches when used. Use of a single cable may result in a *bottle-neck* for the Hyper-V environment, negatively affecting performance of the storage subsystem.
- Enable Flow Control on each switch port used for iSCSI traffic.

- Disable Unicast Storm Control on each switch that processes iSCSI traffic.
- Enable Jumbo Frames on each switch and NIC that processes iSCSI traffic.
- Use the proper iSCSI optimization settings for your iSCSI storage solution. See the documentation for your iSCSI storage solution.
- Disable Spanning Tree Protocol (STP). STP may introduce a large delay before the switch port enters the forwarding mode, introducing undesirable network latency.

Appendix B: Preparing Storage for Your VMs

Use the following procedures to prepare a raw disk for a VM after a LUNs has been provisioned to the parent partition. Dell recommends that you provision one LUN at a time and complete the configuration before provisioning additional disks to avoid selection of the incorrect disk

Preparing the Disk for Use as a Passthrough Disk

- 1 Using **Disk Management** or **diskpart** (for systems running Server Core), confirm that the parent partition recognizes the provisioned disks, and that they have been initialized and are in the offline state.

If using **diskpart**, perform the following commands in order:

- a LIST DISK (note the newly provisioned disk number)
 - b SELECT DISK X (where X is the disk number)
 - c ATTRIBUTES DISK CLEAR READONLY
 - d ONLINE DISK
 - e CONVERT GPT (initializes the disk)
 - f OFFLINE DISK
- 2 If the disk is to be utilized for a highly available VM, make the disk a cluster resource.
 - 3 Present the disk to the virtual machine using Hyper-V Manager.

Preparing the Disk for Storing VHDs or VM Files

Both VHDs and VM files (configuration, saved state data, etc) must reside on a formatted partition. Perform the following steps after provisioning LUNs to the parent partition:

- 1 Using **Disk Management** or **diskpart**, place an NTFS partition on the provisioned disks and assign a drive letter to the partition. It is recommended to utilize a GPT partition type based on their improved partition data structure integrity when compared to MBR and support for LUNs greater than 2 TB.

If using **diskpart**, perform the following commands in order:

- a LIST DISK (note the newly provisioned disk number)
- b SELECT DISK X (where X is the disk number)
- c ATTRIBUTES DISK CLEAR READONLY
- d ONLINE DISK
- e CONVERT GPT (initializes the disk)
- f CREATE PARTITION PRIMARY
- g FORMAT FS=NTFS LABEL="LABEL" QUICK
- h ASSIGN LETTER=Y (where Y is an available disk letter)



NOTE: If your configuration has a large number of disks and will exceed the 26 drive letters available, mount points can be utilized. For more information on mount points, refer to the Microsoft TechNet article, *Assign a mount point folder path to a drive* at technet.microsoft.com.

- 2 If the disk is to be utilized for a highly available VM, make the disk a cluster resource.
- 3 Create VHDs for the virtual machine using Hyper-V Manager.

Appendix C: Glossary

BFI — Booting a system from a LUN residing on a iSCSI storage array

GUEST OS — The operating system that is running within a virtual machine.

HYPER-V MANAGER — The Microsoft Management Console (MMC) that manages the Hyper-V Virtualization Role on Windows Server 2008.

HYPERVISOR — A layer of software that sits just above the hardware and below the parent partition and VMs. Its primary job is to provide isolated execution environments called partitions. Each partition has its own set of hardware resources (CPU, memory, and devices).

LUN (LOGICAL UNIT NUMBER) — In this solutions guide, a LUN refers to a unique disk that is provisioned to a server from a storage enclosure or array. For the MD3000 and MD3000i, the documentation and user interface refer to a LUN as a virtual disk.

MPIO — Multi-Path IO provides fault-tolerance and performance enhancements by implementing more than one physical connection path from servers to storage.

PARENT PARTITION — A partition that is created first and owns all the resources that the hypervisor does not own including most devices and system memory. It hosts the virtualization stack, and creates and manages the child partitions.

PASSTHROUGH DISK — Disks that are mapped directly to VMs and provide raw access to the underlying physical disk.

STORAGE ARRAY — A collection of disks external to the server that support an advanced feature set including RAID and memory caching. For Dell, this category includes iSCSI, fibre channel, and SAS storage arrays.

STORAGE ENCLOSURE — A collection of disks external to the server contained within a single enclosure. The enclosure does not contain an internal RAID controller. Commonly referred to as a JBOD.

VHD — Virtual Hard Disk. Mimics the capabilities of a physical disk for a VM and encapsulates logical blocks within a single file.

VM — A Hyper-V Virtual Machine.

VM FILES — The virtual machine configuration, device state, and memory (XML, VSV, and BIN) files.

Appendix D: References

- Dell Solutions for Windows Server 2008 Hyper-V at www.dell.com/hyper-v
 - *Dell Virtualization Solutions Advisor Tool*
 - *Dell Solutions Overview Guide for Microsoft Hyper-V*
 - *Dell Networking Solutions Guide for Microsoft Hyper-V*
 - *Dell Storage Solutions Guide for Microsoft Hyper-V*
 - *Dell Virtualization Reference Architecture for Microsoft Hyper-V*
- *Hyper-V RTM Update - Microsoft KB950050* from <http://support.microsoft.com>
- *How to Install Windows Server 2008 Hyper-V* from <http://www.microsoft.com/windowsserver2008/en/us/hyperv-install.aspx>
- *Windows Server 2008 Hyper-V FAQ* from <http://www.microsoft.com/windowsserver2008/en/us/hyperv-faq.aspx>
- *Microsoft Virtualization and Consolidation with Hyper-V* from <http://www.microsoft.com/windowsserver2008/en/us/virtualizationconsolidation.aspx>
- *Supported Guest OS in Windows Server 2008 Hyper-V* from <http://www.microsoft.com/windowsserver2008/en/us/hyperv-supportedguest-os.aspx>
- *Windows Server 2008 TechCenter* from <http://technet.microsoft.com/en-us/windowsserver/2008/default.aspx>

